

Maharashtra Insecticides Limited

(A Subsidiary Company of M.A.I.D.C. Ltd., Mumbai)
(Incorporated under Companies Act. 1956)



MUMBAI OFFICE
C/o. The Maharashtra Agro-Industries
Development Corporation Limited.
Krushi Udyog Bhavan,
Aarey Milk Colony Compound,
Goregaon (East), Mumbai – 400 065.
Tel. : 29272027 Fax : 28719398 / 99

GST No. 27AABCM8932B1ZM
CIN No.UG24210MH1984SGC032856
CIN No.UO5000MH1965SGC013380

Expression Of Interest (E.O.I.) Notice

Ref.No. Pest/MIL/EOI/2023-24/42

Date: 18.04.2023

To,
M/s,-----

Subject: Invitation for Expression of interest (EOI) from the reputed Manufacturers/Traders to solicit interest for supply of Pheromone Traps, Sticky Traps, Silicon Septa Lures (5 types) in “Krushi-Udyog” brand to MAIDC Ltd./MIL for the year 2023-24 in the state Maharashtra and Other State also.

Dear Sirs,

Online digitally signed Expression of Interest are invited from the manufacturer/
Traders for the following options -

1. The supply of above Pheromone Traps and Lures on FOR basis to anywhere in Maharashtra or our various Regional Office go-downs, as per specification (**See Annexure-A for Specification/ design/ sketch of Pheromone Traps, Sticky Traps, Silicon Septa Lures**)
2. Supply of Pheromone Traps and Lures on FOR basis to anywhere in Maharashtra (to Govt. Agril. Offices up-to Taluka / Mandal Level) or our various Regional Offices/ MIL Akola as per demands. (**See Annexure-E** the list of Office Addresses).

3. **Background (About MAIDC Ltd. a Govt. of Maharashtra Undertaking).**

MAIDC Ltd. is engaged in the Fertilizers, Pesticides, Cattle Feeds, Food Processing and Agro Engineering business since 1965. The Pesticides Division is having two Pesticide Formulation units of its subsidiary company Maharashtra Insecticides Ltd. situated at Akola and Lote Parshuram, Pesticides are formulated under the brand name 'Krushi Udyog'. This brand name has established goodwill in the farmers since last 56 years. MAIDC/MIL is also Manufacturing & Selling of various new Pesticides, Fungicides, Weedicides and others through its strong dealer's network in Maharashtra State.

4. **ELIGIBILITY CRITERIA FOR THE TENDERERS:-**

1. Manufacturers / Traders are eligible for participation having proven track record.
2. They should have mentioned available facilities (Required plant and machinery for manufacturing of Pheromone Traps and Lures with monthly production capacity, Supply Capacity, Storage Capacity etc..)
3. Necessary Factory Inspection will be carried by our officials if required.

5. **Quality Aspect:-**

The quality norms will be strictly as per Specification mentioned in Annexure-A and maintaining the quality as aforesaid will be the sole responsibility of the successful bidder. For further details, please refer the Terms and Conditions - Annexure "D" and for specification - Annexure "A".

- 1) Pheromone Traps specification should be approved (Tested) by **CIPET** (Central Institute of Plastic Engineering Technology, Aurangabad) is necessary.
- 2) Lures specification /Testing of Semi chemicals should be tested by Any Govt. Laboratory OR **Indian Institute of Chemical Technology, Hyderabad** is necessary.
- 3) Testing charges are born by the tenderer.

6. **Contract Period:-**

The EOI is invited for **the period of one year i.e. April 2023 to March 2024**. However, the interested bidders submitting their proposals must be able to commit to engage with MAIDC Ltd./MIL for at least 3 years if desired so by MAIDC/MIL and on mutual understanding.

7. **Rates:-**

The rates quoted by the bidder shall be most competitive. The rates quoted should be on FOR destination basis inclusive of insurance, freight including loading/ unloading etc. with detail bifurcation such as basic net rate, GST etc. on **Back to Back basis**. Further, it may be noted that any bidder if tempted to quote the rate below the cost of production of a product or abnormally high price, than ruling market price, such tenders will be summarily rejected.

No rate revision will be considered by MAIDC/MIL during the contract period.

- 8) **Packing:** - a. Traps - 100 Nos. of Traps (Full assembly) pack in CRT box with proper packing.
b. Lures - 100 Nos. of Lures packed in separate CRT box with proper packing.
C. For each batch of product quantity is not more than 1,00,000/- units/Nos.

9. **Legal Aspect:-**

For the supply of products, purchase order will be issued as usual. However the successful bidder will have to execute an MOU regarding the terms and conditions governing the supply of Pheromone Traps and Lures mentioned above on the non-judicial bond paper.

In case of any legal dispute arising during the contract period the jurisdiction will be the Court of Mumbai only.

10. **MAIDC/MIL reserves the right to accept or reject any or all the offers at its sole discretion without assigning any reason.**

Contact Address :-

**Pesticides Division,
Maharashtra Agro Industries Development Corporation Ltd.
Krushi Udyog Bhavan, Dr.Dinkar Desai Marg,
Goregaon (E) , Mumbai-65
Official Website : www.maidcmumbai.com
E-mail ID : pesticidesmaidc65@gmail.com**

11. Acknowledgement of Understanding of Terms:-

By submitting a response against the tender, each bidder shall be deemed to acknowledge that it has carefully read all sections of this tender, including all forms, schedules and annexure hereto, and has fully informed itself as to all existing conditions and limitations.

MIL/MAIDC Ltd. may, in exceptional circumstances and at its discretion, extend the deadline for submission of tender response by issuing an addendum to be made available on the MAIDC Ltd.'s website and e-tender website in which case all rights and obligations of MIL/MAIDC Ltd. and the interested bidders previously subject to the original deadline will thereafter be subject to the deadline as extended.

12. Online Submission :-

The Tender document along with the Terms & Conditions can be downloaded from the e-tendering portal <https://mahatenders.gov.in> by paying online **Rs. 10,400/- (Ten Thousand Four Hundred only)** (non refundable) . The payment can be remitted through net banking only.

The interested bidders will have to pay online, the **Earnest Money Deposit of Rs. 5,00,400/- (Rupees Five lakh four hundred only)** by way of net banking at the time of bid preparation. Earnest Money Deposit of successful bidder will be converted into Security Deposit. For details please refer Terms and Conditions. (Annexure - D).

Interested bidder will have to submit online offers for FOR delivery basis in the BOQ format provided in **Commercial Bid** only. MAIDC/ MIL strictly prefers the FOR delivery terms which may please be noted.

It is necessary for the tenderer to submit five samples each, All types of Pheromone Traps (full assembly) and Lures within 7 days after closing of tender. If tenderer not able to submit samples within time the management have right to reject the bidder from this tender.

The Tenders are liable for rejection due to the following reasons:-

1. Incomplete / non-submission of any of the documents sought for.
2. For any disqualification made by the Corporation.
3. Default in the previous transaction.
4. Incomplete technical and commercial bids.
5. After technical bid opening, MAIDC/MIL Officer will visit to manufacturers to check the eligibility of tenderer and only after satisfactory report further agreement will be done.
6. If minimum requirement is not (as per quoted quantity, Plant and machinery/facilities etc.) available at the time of inspection and the sample is not matched/failed with mentioned specification/design/sketch in Annexure-A, MIL/MAIDC have right to disqualify the said bidder.

7. The tenderer are responsible for quality parameters etc.
8. Special Note: -
 - a. Tenderers is instructed to read all General terms and conditions as per annexure "D" enclosed.
 - b. Corporation reserve right to decide (embossing/labeling) suitable/modified procedure for production and supply of Pheromone Traps/Lures under MIL brand including pre-delivery inspection and supply on MIL delivery challlan etc. and draft suitable agreement/MOU to govern this supply.

Thanking you,

Yours faithfully,
For The Maharashtra Insecticides Limited.
Sd/-
(Jyoti Deore)
Dy.Gen.Mgr.(Pest) / ED (MIL)

**The M. A. I. D. C. Ltd/ M.I.L. Ltd
Pesticides Division, Mumbai.**

List of Technical Bid Documents T-1

1. Copy of Registration Certificate of Firm / Organization / Manufacturing License / MSME by Industries Department.
2. Corporate Identity Number i.e. CIN No. in case of Company (If applicable).
3. Copy of GST registration certificate.
4. Details of Production and Sale for last three years on bidders letter head (authorized by CA).
5. Company details in Annexure "C" attached herewith.
6. The Pheromone Traps and Lures should be approved by ICAR or any State Agriculture Universities. (Approved copies/Lab reports of Lures should be enclosed with tender Documents in Technical envelope.)
7. Acceptance of General Terms & Condition as per Annexure "D" (Bidder should upload all the pages of General Terms & Condition with proper stamp, seal & sign.)
8. **For the purpose of Quality supply, bidders must have experience of supply of Pheromone Traps & Lures to MIL / MAIDC / Govt. of Maharashtra/ Any Govt. Department/ Authorities for preceding last three years. (Bidder should submit Concern authority certificate should be attached herewith)**

Tender Schedule (key dates)

Tender Release Date & Time	Closing Date & Time	Opening Date & Time
18.04.2023	01.05.2023 15.00	03.05.2023 15.05

Yours faithfully,
For The Maharashtra Insecticides Limited.
Sd/-
(Jyoti Deore)
Dy.Gen.Mgr.(Pest) / ED (MIL)

The M. A. I. D. C. Ltd./ M.I.L Ltd
Pesticides Division, Mumbai
Instructions for the Interested bidders

Interested bidders are requested to visit the website <http://mahatenders.gov.in> and go through the “e-tendering Tool Kit” wherein all the basic **know how** (detailed help documents designed for Interested bidders) of the e-tendering stages are given.

The interested bidders are required to download the tender documents for the above items online and submit their Bids for these items online ONLY. Manual tender response shall not be considered in any circumstances.

The various activities required to be executed by the interested bidders while submitting their online tender response are time and date locked. The interested bidders are requested to execute all the activities related to their tender response within the prescribed time limits (key dates) for each stage.

The interested bidders will have to make online payment of **Tender Fee Rs. 10,400/-** and **Earnest Money Deposit (using only net banking) of Rs. 5,00,400/-**

As per Information Technology Act – 2000, the interested bidders are required to sign the bid documents using Class – II / Class – III Digital Signature Certificate. E-Tendering Tool Kit for interested bidders (detailed help documents, designed for interested bidders) has been provided on e-Tendering Website in order to guide them through different stages involved during e-Tendering For more help on Website. 24x7 Helpdesk Toll Free no.: 180030702232 & Mobile No. 917878107985-86/917878007972-73 For further information, please visit <https://mahatenders.gov.in>

The MIL/MAIDC reserves the right to accept or reject any or all tender response either in part or in full without assigning any reason whatsoever.

Tender opening

The tenders will be opened at on ****.2023 at 15.05 PM in presence of bidders or their representative if present.

Yours faithfully,
For The Maharashtra Insecticides Limited.
Sd/-
(Jyoti Deore)
Dy.Gen.Mgr.(Pest) / ED (MIL)

Annexture -A

A) Specification of Pheromon Traps :-

1. **Colour** :- Light Green only, specified in sketch/design.
2. **Structure** :- The Pheromon Trap may have four parts- Canopy, Funnel trap base, fixing ring and collection device made by virgin plastic.
3. **Details of Pheromon Traps** :-

Sr.No.	DESCREPTION	Outer Dimension	Height	Thickness	Weight	Material
1	TOP PART (Canopy)	Φ143 mm.	13.5 mm.	1.15 mm.	20 ±1gm.	PP (VIRGIN)
2	MID PART (Fixing Ring)	Φ149 mm.	47 mm.	2.0 mm.	9.8 ±1gm.	PP (VIRGIN)
3	FUNNEL (Funnel Trap Base)	Φ114.3 mm.	68 mm.	0.8 mm.	14.9 ±1gm.	PP (VIRGIN)
4	PE FILM (Collection Device)	Φ114.5 mm.	600 mm.	50 micron	-	PE
5	SILICON SEPTA (Lures)	Φ9.3 mm.	19 mm.	-	-	SILICON BASE
6	VAIL Lure	Φ9 mm.	34 mm.	7 mm.	1 ± 0.2gm.	PE (VIRGIN)
7	CAP	Φ7 mm.	5 mm.	2.0 mm.	0.2 ±0.1gm.	PE (VIRGIN)

4. **Top part - Canopy** :-

- a) Provision for fixing the canopy to the Trap Base and the Pheromon Lure.
- b) Colour :- Light Green
- c) Details are mentioned in Design/Sketch.

5. **Mid part - Fixing Ring** :-

- a) Ring should have handle for fixing the trap.
- b) Ring is provided with three stalks for fixing the canopy to the trap base.
- c) Colour :- Light Green
- d) Details specification is mentioned in design/sketch.

6. **Funnel Trap Base** :-

- a) Colour :- Light Green
- b) Details specification is mentioned in design/sketch.

7. **Collection device**:-

- a) It is made of Polypropylen
- b) Colour :- Colorless
- c) Details specification is mentioned in design/sketch.

Pheromone Traps with Lures detail Design/Sketches with proper dimension

1) **Full Assembly :-**

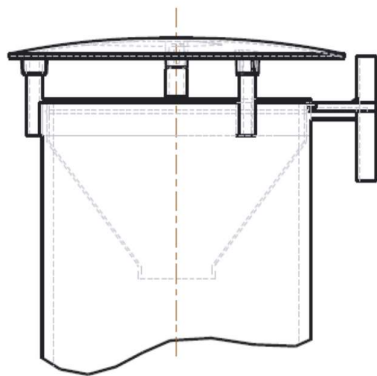
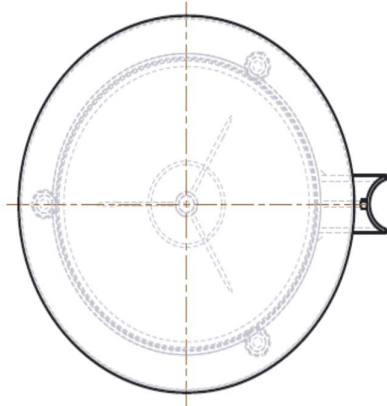

IMAGE

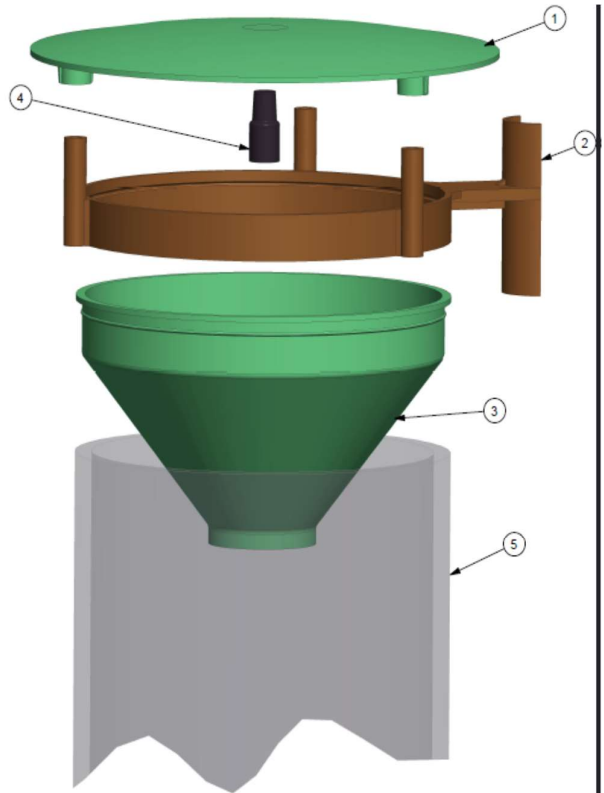

NOTE : ALL DIMENSIONS ARE IN MM.
IF ANY DOUBT PLEASE ASK.

CENTRAL INSTITUTE OF PLATICS ENGG. & TECHNOLOGY AURANGABAD				NAME	SIGN/DATE	MODEL:FUNNEL TRAP	
5	POLYETHYLENE	01		DRWN.	Mr.MOHD. ASIF	26-02-2018	ASSEMBLY
4	SILICON SEPTA	01		CHK.	Mr.ARUN PRASAD		Mtl. - PP (VIRGIN)
3	FUNNEL	01		APPD	Mr VFDHACHAI AM		SCAI F-NTS
2	MID PART	01					
1	TOP PART	01					
P&T No.	DESCRIPTION	QTY	REMARKS	APPD	Mr VFDHACHAI AM		SCAI F-NTS

2) Top part (Canopy) -

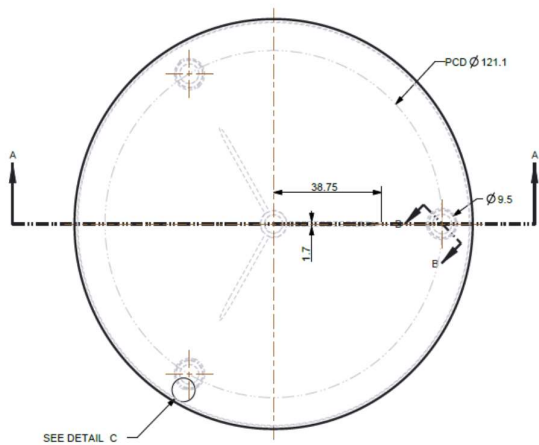

SEE DETAIL C

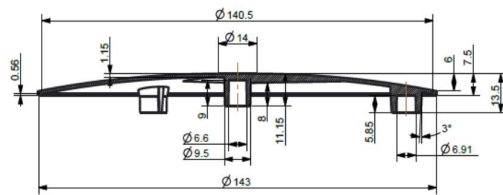
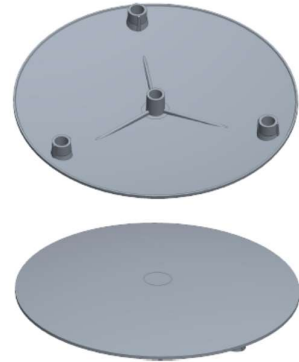
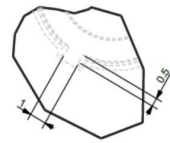
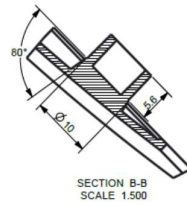

SECTION A-A

NOTE : ALL DIMENSIONS ARE IN MM.
IF ANY DOUBT PLEASE ASK.

CENTRAL INSTITUTE OF PLATICS ENGG. & TECHNOLOGY AURANGABAD			
	NAME	SIGN/DATE	MODEL: TOP PART
DRWN.	Mr.MOHD. ASIF	21-02-2018	Mtl. - PP (VIRGIN)
CHK.	Mr.ARUN PRASAD		Weight- 20gm.
APPD.	Mr.VEDHACHALAM		SCALE- NTS

3. Middle part (Fixing Ring)-

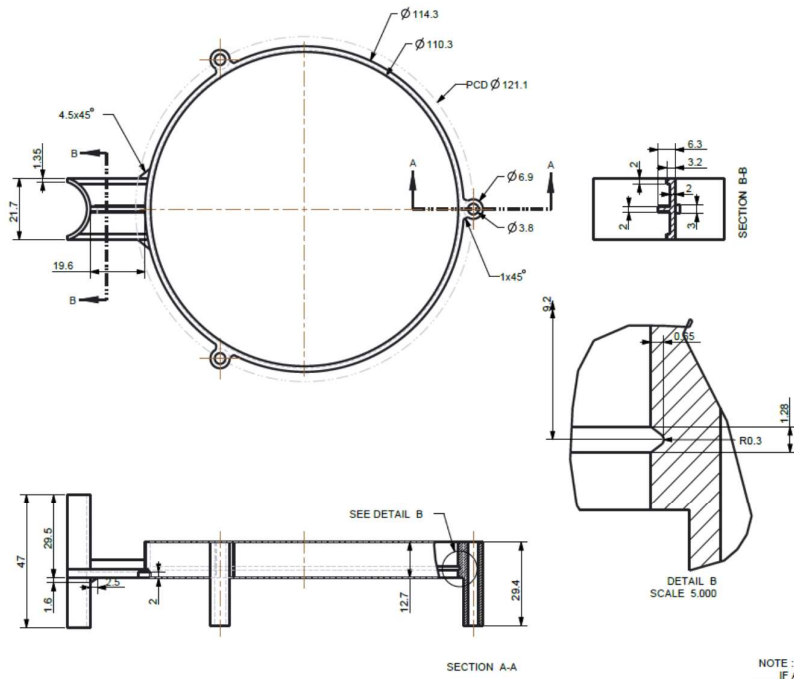

NOTE : ALL DIMENSIONS ARE IN MM.
IF ANY DOUBT PLEASE ASK.

CENTRAL INSTITUTE OF PLATICS ENGG. & TECHNOLOGY AURANGABAD			
	NAME	SIGN/DATE	MODEL: MIDDLE PART
DRWN.	Mr.MOHD. ASIF	26-03-2018	MIS - PP (VIRGIN)
CHK.	Mr.ARUN PRASAD		Weight- 13 ± 1 gm.
APPD.	Mr.VEDHACHALAM		SCALE- NTS

4). Funnel Trap Base and Collection Device-

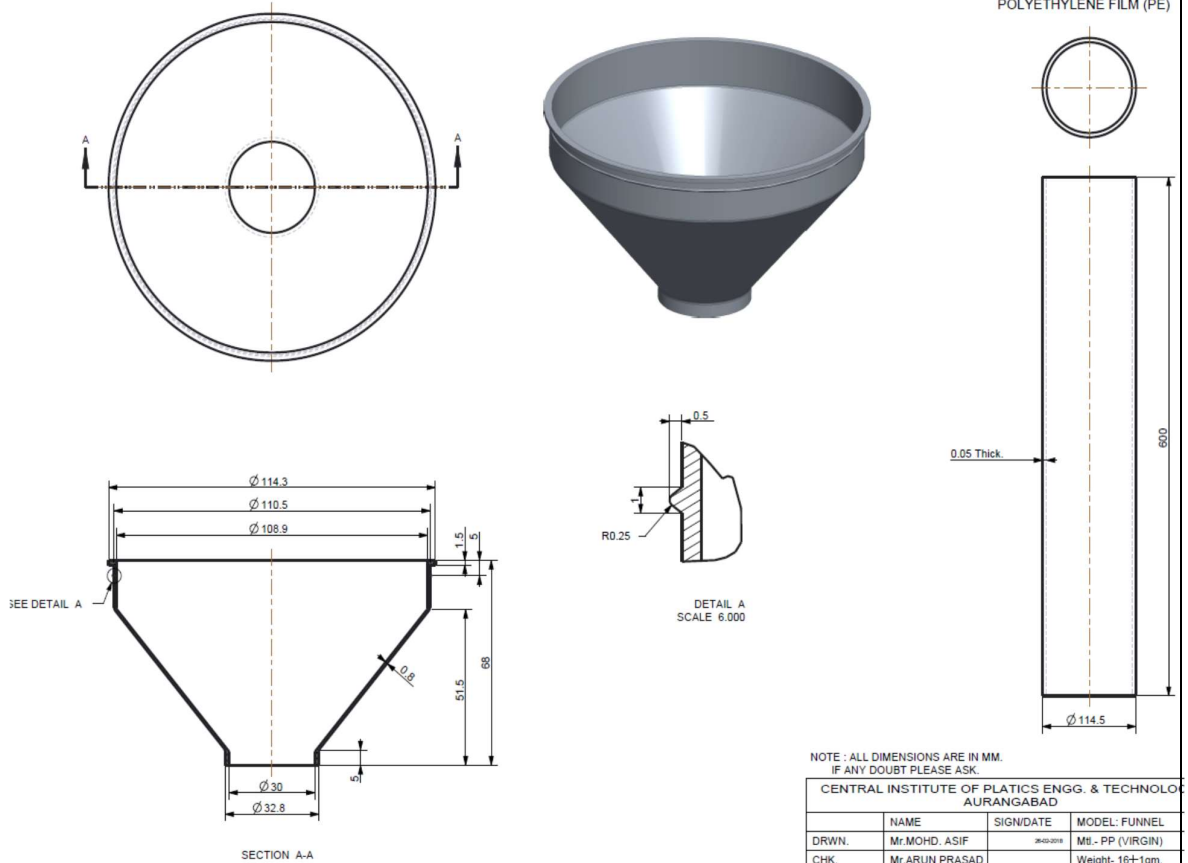

B) Specification of Lures (Silicon Septa) :-

1. Size :- The Lures (Silicon septa) Diameter, Height, Thickness etc. details mentioned/Specified in attached design/Sketch.
2. Colour :-
 - a) Helicoverpa armigera Lures
 - b) Pectinophora gossypiella Lures
 - c) Spodoptera litura Lures
 - d) Scirpophaga incertulas Lures
 - e) Spodeptera frugiperda (FAW)
3. Lures made of Silicone Septa impregnated with pheromone blends.
4. Each Silicone Septa is impregnated with minimum 5 micro liter of pheromone blend.
5. Field efficacy should be minimum for 45 days after application.
6. Impregnated lures are packed singly in individual trilaminated film pouch.
7. Shelf life of lure in original pack is minimum 12 month at room temperature.
8. Lures must attract insect species only, with 50% insect attractancy by Pheromon lure.

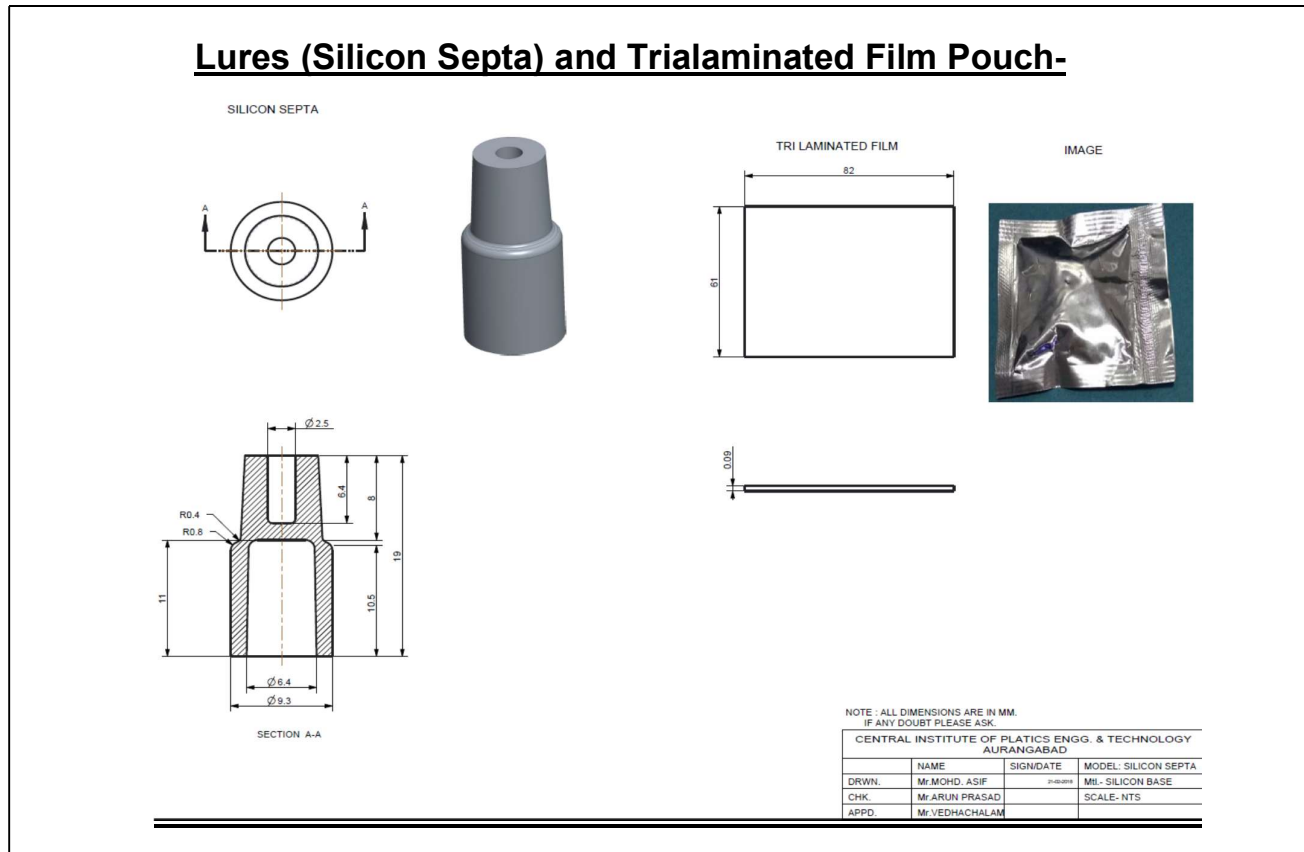

Note :-

1. Bidders are strictly noticed to use Raw materials are mentioned in specification.
2. In transportation any damage/thefts are born by bidder only.

C. Details of Composition of Impregnation Blend (Pheroman blend) for various Lures types :

- **Composition of Impregnation Blend (Pheroman blend) for Helicoverpa armigera :-**
 - a. Z9 - Hexadecenal (Minor component)
 - b. Z11- Hexadecenal (Major component)
 - c. Ratio :- 2:9/3:97(Minor:Major)

- **Composition of Impregnation Blend (Pheroman blend) for Spodoptera litura :-**
 - a. (Z,E) 9,11 - Tetradecadienyl Acetate (Major component)
 - d. (Z,E) 9,12 - Tetradecadienyl Acetate (Minor component)
 - b. Ratio :- 90:10 (Major:Minor)

- **Composition of Impregnation Blend (Pheroman blend) for Pectinophora gossypiella :-**
 - a. (Z,Z) 7,11 - Hexadecadien - acetate
 - b. (Z,E) 7,11 - Hexadecadien - acetate
 - c. Ratio :- 50:50 (Minor:Major)

- **Composition of Impregnation Blend (Pheroman blend) for Scirpophaga incertulas :-**
 - a. (Z) 11 - Hexadecacinal
 - b. (Z) 9 - Hexadecacinal

- **Composition of Impregnation Blend (Pheroman blend) for Spodeptera frugiperda:-**
 - a. (Z) 7- dodecenyl acetate
 - b. (Z) 9 -dodecenyl acetate

Note :-

1. Pheromone Traps specification should be approved (Tested) by CIPET, Aurangabad (Central Institute of Plastic Engineering Technology)
2. Lures specification/testing of Semi chemicals should be tested by Any Govt. Laboratory OR Indian Institute of Chemical Technology, Hyderabad is necessary.

E) Sticky Trap's Specification : -

- (1) These Traps are made of PP Flute Board
- (2) Both side of the board are coated with high quality rain fast gum.
- (3) Each trap will be covered with released paper from both sides. Not like economic version where top and bottom have two release papers for one bundle.
- (4) Plastic Yellow / Blue Sheet –**325 gm** (+/-5%).
- (5) Gum Coating –**40 gm** (+/-5%).
- (6) Gum Warranty – more than 12 months.
- (7) Trap Type **25 pieces in 1 Bundle.**
- (8) Traps Available in both size **2.5 mm.**

Size In mm	Size In Inches	Type	Qty/ Box
150*200	6*8	2 in 1	1000 Numbers

To Be Print on Suppliers LETTER HEAD

ANNEXURE "C"
Format of company information

Name of the company:-	
Registered office address:-	
Address for correspondence:-	
Name of the authorized signatory	
Designation of the authorized signatory	
Mobile No. of the authorized signatory	
Name of the other contact person	
Designation of the contact person	
Mobile No of the contact person	
Land line Nos. of the company	
Fax Nos. of the company	
E-mail address of the company	
GSTN	
PAN No. of the company	
Production details for last three years	
Company's annual turnover for last three years	
Bank details of the company for payments by RTGS a) Beneficiary Name:- b) Credit account No.:- c) Centre (Location):- d) Bank Name:- e) Branch address:- f) Account type:- g) IFSC Code:-	

Also please enclose a cancelled cheque of above account for our ready reference.

Name & Designation of
Authorized signatory

:

Authorized Signature of
Bidder with seal

Annexure -E

List of Regional Offices and Address:- Regional Offices

<p><u>R. O. Akola</u> 9011126357 <u>Shri .C.P.Salunkhe/ 8888842357</u> Civil Line Load, Infront of Radio Station,Next to I.M.A Hall, Akola – 444001. Tel No- 0724-2426021/2437172 Email –maidcraakola@gmail.com</p>	<p><u>R. O. Jalgaon</u> <u>Shri.Ingale / 8888842351</u> Plot No. 48, zillasahkar Board Housing Soc., Jalgaon -425001. Fax No. -0257-2240571 Tel No- 0257-2239488 / 2221729/2236108 Email – jalgaonmaidc@gmail.com</p>
<p><u>R. O. Amaravati</u> <u>Shri. S.K.Thosre/8888842353</u> ChaudhariComplex,Chaudhari Chowk, Cotton Market, V.M.V. Road, Amravati – 444601. Fax No. -0721-2579584. Tel No- 0721- 2562065/2563023 Email- maidcamravati@gmail.com</p>	<p><u>R. O. Kolhapur 8888842344</u> <u>Shri. R.A.Patil / 9423644137</u> 517/E Maharani Tarabai Chowk, Kawala Naka, Kolhapur – 416001, Fax No. 0231-2536563 Tel No.- 0231-2537811/ 2537682 Email –rokolhapurmaidc@gmail.com</p>
<p><u>R. O. Aurangabad</u> <u>Shri. D.R.Chavan / 8888842340</u> Shakti Sahakar, Opp. State Transport Divisional Workshop, Aurangabad – 431001. Fax No. 0240-2361455 Tel No- 0240-2332190/2321332 Email –aurangabadmaidc@gmail.com</p>	<p><u>R. O. Nagpur</u> <u>Shri. Rathod K.G../8888842290</u> <u>Deepak Bandhe 8888842328</u> Plot No.B-17 to B-20MIDC, Behind Bhagat Petrol Pump, Noga Factory, Hingna, Zila Nagpur., Fax No. 0712-2729973 Tel No. 0712-2720228/2720314 Email –maidcronagpur@gmail.com</p>
<p><u>R. O. Chandrapur</u> <u>Shri. Pramod Pethe / 8888842342</u> Popat Building, 2nd Floor Purlo Bazar, Nr. Jatpura, Chanrdapur -442401. Fax No. 07172-272314 Tel No- 07172-255913 Email- rochandrapurmaidcmumbai@gmail.com</p>	<p><u>R. O. Nanded</u> <u>Shri.P.R.Phad/ 8888842343</u> “Samruddhi” New Mondha, Near State Bank, Nanded. Fax No. 02462-285011 Tel No- 02462-285011/285012 Email –maidcronanded@gmail.com</p>
<p><u>R. O. Nashik</u> <u>Shri. RavindraPatil / 8888842396</u> Deolali Naka, New Mumbai Agro Road Mahamarg, Nashik – 422001. Fax No. 0253-2594893. Tel No 0253-2595879/2594978 Email –maidcnashik@gmail.com</p>	<p><u>R. O. Ratnagiri</u> <u>Shri. A.T.Kale 8888842303/</u> <u>Vijay Bawkar 9594302443</u> <u>(Acctts.&Amn.) (Addl.Charge)9881075900</u> Plot No.p-73,MIDC Area, MirijoleDist, Ratnagiri- 415612. Fax No. 02352-230520, Tel No. 02352-230518 Email –maidcratnagiri@gmail.com</p>
<p><u>R. O. Osmanabad</u> <u>Shri.M.B.Vatkar/ 8888842384</u> Anand Krupa 2nd Floor, Near Immersion River, Naikwadi Nagar, Osmanabad – 413501. Mob.No. 8888842275, 8888842363 Tel No. 02472-222067/ 223318/224130 Email –osmanabadmaidc@gmail.com</p>	<p><u>R. O. Thane</u> <u>Shri Nitin Jadhav / 8888842293</u> KrushiudyogBhavan, Dinkarrao Desai Marg, Aarey Milk Colony, Goregaon (E), Mumbai- 400065. Fax No. 022-28719399, Tel No. 022-29272530 Email – rothane93maidc@gmail.com</p>
<p><u>R. O. Pune</u> <u>Shri. Zende / 8888842281</u> Plot No. 653 to 660 Gultakdi, Market Yard, Pune- 411037. Fax No. 020-24264881 Tel No. 020-24263985/24263986, Email – punemaidc@gmail.com</p>	<p><u>Maharashtra Insecticides Ltd</u> C.E.O.- Shri Patharkar Vijay 8805010529, C-4, MIDC Area, Shivani, Dist- Akola Pin 444104 Email- milakola1@gmail.com</p>

(Annexure-D)
MAHARASHTRA INSECTICIDES LTD.

(C/O. THE MAHARASHTRA AGRO IND. DEVELOPMENT CORPORATION LTD.)
KRUSHIUDYOG BHAVAN AAREY MILK COLONY, DINKARRAO DESAI MARG,
GOREGAON (EAST), MUMBAI 400 065.

GENERAL TERMS AND CONDITIONS.

1) Terms and conditions hereinafter shall be binding on the tenderer & MIL Ltd. These terms and conditions shall come into effect immediately when the tenderer submit his tender along with Earnest Money Deposit to **MAHARASHTRA INSECTICIDES LTD.** at Mumbai Office address.

2) **DEFINATION & INTERPRETATION:**

In this contract for the General and Special terms and conditions the words will have the following meanings unless the context otherwise requires.

- a) “**Acceptance of tender**” means the letter or memorandum communicating to the tenderer for acceptance of this tender.
- b) “**Contract**” means invitation to tender, instructions to tenderers, acceptance of tender, particulars and the general and special conditions specified. In the acceptance of tender that includes repeat order which has been accepted or acted upon by the tenderer.
- c) “**Tenderer**” means the person/firm/company with whom the contract is made and includes his legal heirs, executers, administrators or successors and permitted assigns, as the case may be.
- d) “**Purchaser**” means any person who is authorized by Executive Director, Maharashtra Insecticides Ltd. to deal with the tenderer.
- e) “**Executive Director**” means The Executive Director of Maharashtra Insecticides Ltd.
- f) “**Officer**” means any person who is authorized by Executive Director of Maharashtra Insecticides Ltd. to deal with the tenderer.
- g) “**Material**” means all items mentioned in the purchase order/memorandum communicating the acceptance of tender.

3) **PARTIES:**

The parties to the contract are the tenderer and the purchaser.

4) **SUBMISSION OF TENDER QUOTATION:**

Tenderer should submit their tender via e-tendering system on site

[“https://mahatenders.gov.in”](https://mahatenders.gov.in)

5) **AUTHORITY OF PERSON SIGNING THE CONTRACT ON BEHALF OF THE TENDERER :**

The tenderer shall disclose the nature, constitution and registration of the tendering firm and the tender shall be signed by a person or persons duly authorized

to do so by means of legally valid documents which or a duly certified copy of the same shall be attached with the tender.

OR

A person signing the tender or any documents in respect of the contract on behalf of the tenderer without disclosing his authority to do so shall be deemed to warrant that he has authority to bind the tenderer. If it is discovered at any time that the person who is signing had no authority to do so, the Executive Director may, without prejudice to any other right to remedy of the purchaser, cancel the contract in the part or full and or purchase the material at the risk and cost of such a person and hold such person liable to the purchaser for all cost damages arising from the cancellation of the contract including any loss which the purchaser may sustain on account of such purchaser.

- 6) Address of the tenderer and notice and communications shall be sent unless the tender has noticed the change by separate letter containing no other communication and sent by Registered Post acknowledgement due to the Executive Director or to the officer. The tenderer shall be solely responsible for the consequences of an omission to notify a change of address in the manner aforesaid. Any communication and notice on behalf of the purchaser, in relation to the contract may be issued to the tenderer by office and all such communication and notices may be served on the tenderer either by registered post or under certificate of posting or by ordinary post or by hand delivery at option of such officer.

7) AUTHORITY OF THE EXECUTIVE DIRECTOR/OFFICER :

For all the purposes of the contract including arbitration proceeding therein, the Executive Director and/or officer shall be entitled to exercise all the rights and powers of the purchaser.

- 8) The purchaser shall scrutinize all the tenders received by them. The tenders shall be opened on the day and time fixed in advance. The tenderer shall be at liberty to remain present at the time of opening tenders. After scrutinizing the tenders it shall be the right of the purchaser either to accept a single or more tenders and/or to reject any one or all the tenders. The purchaser shall not be bound to give any reason either for acceptance or rejection of tender. **No correspondence / communication/ compensation claim in this respect from tenderers shall be entertained.**

- 9) **REJECTION OF TENDER:** Any tender,
Which varies from our terms & conditions or stipulate counter conditions

OR

Which fails to provide required information or is otherwise incomplete.

OR

Which is received from the tenderer/his partner having implicit or explicit relations with the employee of the purchaser is liable to be rejected.

10) ACCEPTANCE OF TENDER:

The acceptance of tender will rest with the purchaser, which does not bind itself to accept the lowest tender and reserves to itself the right.

- a) To reject any or all tenders,
- b) To split the purchase amongst two or more tenderers–Purchaser will split the purchase amongst tenderers finalized at its sole discretion.**
- c) Purchaser reserves the right to split the purchase in whole or in part without assigning any reason whatsoever.**
- d) Purchaser does not guarantee any minimum quantity during the tenure of the contract.
- e) To negotiate with one or more tenderers for revision of rates downwards if the purchaser feels that the rates so received are not appropriate.
- f) To reject the tender on the basis of unsatisfactory performance of the tenderer in subject or previous contract with the purchaser.
- g) To reject the tender of delisted tenderer by any other company due to unsatisfactory performance, forfeiture of EMD or any other similar reason.
- h) To reject the tender having financial or business association with the purchaser's employee.
- i) When tenders are received from any proprietorship/firm/companies having the same proprietor or one or more partners/Directors in the business organization of any other party (hereinafter called common firms), such tenders shall be considered as having been received from only one applicant in different names and the lowest acceptable quotation of such common firm shall only be considered for evaluation.
- j) When tenders are received from any proprietorship/firms/companies having one or more common business facilities such as CIN No. telephone, fax, emblem, address etc. shall be considered as having been received from only one tenderer in different names and the lowest acceptable quotation of such common firm shall be considered.

11) ASSIGNMENT OR SUBLETTING OF CONTRACT:

The supplier shall not assign or sublet the contract or any part thereof or allow any person to become interested therein in any manner whatsoever without the previous consent in writing of the purchaser, which consent the purchaser shall be entitled to withhold without assigning any reason or ground thereof. Any breach of this condition shall entitle the purchaser to take such steps as may be necessary and also terminate the contract. Such termination shall also render the supplier liable for payment to the purchaser in respect of any loss or damage arising or ensuing from such cancellation. The permitted subletting of work by the supplier, shall not establish any contractual relationship between the sub supplier and the purchaser and shall not release the supplier of any responsibility under the contract. In the event of sufficient dues not being available to compensate for the above, the supplier shall be reimbursed the purchaser for the same by making payment through a demand draft.

12) EARNEST MONEY:

- a) The interested bidders will have to make online payment (using net banking) at the time of entering online bid submission stage of the tender schedule.
- b) That if the tenderer backs out after submission of tender (within the validity period of the tender) and on before or after acceptance of his tender (either whole or in part) the purchaser shall have right to forfeit the amount of earnest money deposit.
- c) Amount of earnest money shall be refunded to the tenderer whose tenders are not accepted by the purchaser as per guidelines of www.mahatenders.gov.in. In case of tenderers whose tenders and or tender are/is accepted by the purchaser, their amount of earnest money deposit shall remain with purchaser till the completion of contract, until accounts are settled.
- d) The small scale industrial units registered with Director of industries, Govt. of Maharashtra and submitting their tenders directly or through State Small Scale Industries Development Corporation or through Meltron or through MAVIM only should pay EMD as specified as per Govt. rule & their amendment time to time , they shall produce necessary proof supporting that they belong to small scale industrial sector.(MSME Certificate)

13) SECURITY DEPOSIT:

- a) Those who are not Govt. Undertaking do not have Govt. participation shall be required to pay Security Deposit. The tenderer whose tender is accepted by the purchaser shall deposit an amount of Security Deposit of Rs. 5,00,000/- in favor of MIL Ltd. The amount of Security Deposit shall be deposited by the tenderer by Cheque/DD/RTGS.
- b) After opening of EOI / E-tender, successful bidders must have to submit Rs 5,00,000/- (Rupees Five Lakh only) as Security Deposit through DD/ R.T.G.S within 10 days from finalization of tender. P.O. will be issued only after fulfillment of aforesaid criteria. If tenderer fails to submit whole amount of security deposit within prescribed time limit, management have rights to reject the tenderer from this tender.**
- c) In case, bidder who had submitted whole or part amount of E.M.D. On request of bidder, E.M.D. amount will be converted into Security Deposit & only balance amount of Security Deposit will be submit as per above (b).**
- d) Security Deposit as above shall be valid for the period of one year, it shall be refunded after due and proper fulfilment/performance of the contract on the part of the tenderer. The Security Deposit (above mentioned) shall be retained by the purchaser during the period of contract till the settlement of the accounts/transactions arising out of the contract. No interest shall be paid on the amount of Security Deposit.
- e) If contract is fulfilled/ completed within the prescribed period and if the period for performance of the contract is extended by the purchaser, in that case tenderer shall have to extend the period of Bank Guarantee and/or furnish fresh Bank Guarantee covering such extended contract during the extended period.

- f) If the tenderer fails or neglects to observe or perform any of his obligations under the Contract, it shall be lawful for the purchaser to forfeit either in whole or in part the Security Deposit deposited by the tenderer. Same as aforesaid if the tenderers duly perform and complete the contract in all respect and presents a certificate of satisfactory completion of contract issued by the "OFFICER", the purchaser shall refund the Security Deposit to the tenderer after deduction of all cost and other expenses that the purchaser may have incurred and all dues and other moneys including of losses and damages which the purchaser is entitled to recover from the tenderer.

14) VALIDITY OF TENDER :- The rates offered by the tenderer shall be valid for acceptance for minimum of 90 days from the date of opening of tender.

15) RATES:

- a) The rates specified in the tender should be exclusive of GST (GST may be mentioned separately) but inclusive of any other taxes, toll, duties of any kind, cess, Interest, royalty or commission in respect of the supply anywhere in the State of Maharashtra. Any other taxes, duties, levies by whatever name called imposed and leviable on the material sold in pursuance of this contract will be borne by the tenderer.
- b) No rate revision will be considered during the period of contract. However any increase/decrease in the statutory Levis will be considered on producing the concerned notification & proof of payment or any other related documents desired by MAIDC Ltd. However, the variation in the statutory duties on account of business turnover/status shall not be considered.
- c) GST paid should be prove after submission of GST invoice, otherwise MIL/MAIDC have right to deduct GST amount from payment of supply.
- d) The tenderer shall quote the FOR rates in given format only at the following address:
**The Maharashtra Insecticides Ltd
Plot No. C-4,MIDC Industrial Area,
Shivani, Akola-444104.**
- e) **Invoice-** The Tenderer should submit commercial tax Invoice in triplicate indicating tax separately to M.I.L.,Akola factory.
- f) The tendered quantity once accepted and purchase order placed with the tenderer by the purchaser, the supplier shall be bound to supply the same. The tenderer should offer only such quantity, which they are in position to supply during the contract period.
- g) At the time of opening of commercial bid any tenderer / bidder is quoted the rates -20% as compared to market rate of succeeding last three months i.e. from 15 Dec 2022 to 15 March 2023 In such case MIL/MAIDC have right to

reject the tender and also reserve the right to black list such tenderer/bidder assuming that he has done this mischievously.

16) PAYMENTS :

The payment of supplied material will be made by the MAIDC/MIL Ltd. after receipt of payment from Govt. Agencies/ Private Dealer along with pre inspection & post inspection report of concern product., i.e. on “Back to Back basis”.

Bills for the supplied material should be prepared in triplicate and sent to the Gen. Manager (F&A/Pesticides), MAIDC Ltd., Goregaon (E), Mumbai 65, and one copy sent to the MIL, Akola. The M.I.L/M.A.I.D.C Ltd. shall not incur any liability to pay interest on the bills for delay in payment. Payment will be made on submission of satisfactory documents and the concerned officer passes it. Payment will be made after fulfilling the following conditions:

- I. GST or any other taxes, duty or earlier if specified in purchase order and handling charges will have to be borne by the supplier.
- II. If shortage or breakage has been reported, the goods should be replaced at his own cost.
- III. If the material is found to be substandard, old or defective the material will not be accepted and supplier will have to replace the material at his own cost.
- IV. Submission of invoices in prescribed time limit is the responsibility of supplier after supply. If any losses arises during tax claim settlement due to late submission of invoices by supplier, such losses will be recovered from supplier's payment.

17) RISK & COST:

The submission of online tender along with the Terms & Conditions duly signed and sealed by the tenderer will be deemed as acceptance of the Terms & Conditions by the tenderer. Once the rates offered by the tenderer are accepted by the purchaser and that if the tenderer backs out after submission of tender and/or acceptance of his tender, the purchaser shall have right to purchase the material on the risk & cost of the tenderer. Tenderer is liable to pay losses incurred by **Maharashtra Insecticides Ltd.** in such transaction. Purchaser reserves the right to blacklist supplier in future participation in the tenders in case of non-supply of indented quantity and or substandard supply.

18) TAXES:

The tenderer should indicate in detail the taxes applicable (percentage of applicable taxes may please be mentioned in the tender) the requirement of submission of various forms under the GST Act. He shall also have to quote is GST registration number on his tax invoice. All invoices should have shown tax elements separately e.g. Basic rate + GST OR any taxes, etc. No inclusive rates should be quoted.

19) PACKING & FORWARDING:

The packing & forwarding charges are to be borne by the tenderer.

20) INSURANCE:

Whenever rate accepted for FOR delivery of the material, the tenderer shall be fully responsible for the breakages/damages and/or losses of the material during the transit. Insurance charges for the material shall be borne by the tenderer.

21) DELIVERY & DELIVERY SCHEDULE:

Tenderer shall deliver the material at the addresses mentioned above.

- a) The Purchaser after placing final purchase order will give the delivery instruction indicating dates, quantity, type of material to be delivered as per requirement time to time. The tenderer shall be bound to effect the deliveries strictly according to dates and specifications and other instructions mentioned therein.
- b) The Purchaser shall have right to make alternations / modifications in the delivery schedule.
- c) That if the tenderer fails to deliver the material or any part thereof within the period fixed for such a delivery the purchaser may, without prejudice to the right of the purchaser, recover damages for breach of contract & if necessary to avoid business loss purchaser will award such supply to other eligible participant bidder
 1. Recover from the tenderer as agreed liquidated damages a sum equivalent to 0.5% of the price of any material, which the tenderer failed to deliver within the period fixed for delivery according to delivery schedule for each week or part of week during which the delivery of such a material may be in arrears where delivery thereof is accepted after expiry of the aforesaid period, however, the amount recoverable under this clause shall not exceed 5% of the order value of the material at delivered rate.
 2. Purchase or authorize the purchase elsewhere without notice to the tenderer, the action and at the risk of the tenderer of the material not so delivered or others of a similar description (where material exactly complying with the particulars are not readily procurable in the opinion of the purchaser which shall be final) without cancelling the contract in respect of the instalments not yet due for delivery or,
 3. Cancelling the contract or a portion thereof and if so desired, purchase or authorize the purchase of the material not so delivered or others of a similar description (where material exactly complying with particulars, are not readily procurable in the opinion of the purchaser which shall be final) at the risk and cost of the contractor.

22) WEIGHMENTS/ SAMPLING:

- a) Weighments, quantity & quality assessment of material certified by purchaser's factory will be final, irrespective of the quantities dispatched & lab test report submitted by tenderer, issued by any laboratories.
- b) Rejected quantities will not be considered.
- c) Contract shall be declared fulfilled if the quantity delivered is 5% more or less than the quantity contracted. Purchaser allows such variation at its own discretion.
- d) The goods shall be inspected at purchaser's option either at purchaser's factory or at tenderer's factory before dispatch.
- e) M.I.Ltd, reserves the right to appoint an inspection Agency for reshipment during the pendency of a contract.
- f) The inspection charges will have to be borne by tenderer.
- g) Random samples will be drawn by MIL of the goods delivered at MIL factory in presence of tenderer or representative of supplier if remains present at the time of delivery at MIL factory. If tenderer intimate their wish to remain present while drawing/sealing of samples at MIL factory site, factory will wait in such case for 48 hours from the date/time of receipt of material, and will draw the samples thereafter. Samples such drawn will be final. Samples drawn will be tested in MIL laboratory and the results will be communicated to the supplier within seven days from the date of receipt of material. In case of dispute regards to quality of the material, joint testing will be done in the presence of supplier's representative. Joint report will be accepted for all purpose. Supplier should send his representative for joint testing within seven days from the date of receipt of test report, otherwise MIL's report will be considered as acceptable to supplier.

23) REJECTION OF SUPPLIES:

- a) The material supplied if not conforming to the specifications shall be rejected by M.I.Ltd., at their sole discretion. If any material is rejected by the M.I.Ltd., then at their sole discretion shall exercise any one or more than one of the following.
 - i. To allow the tenderer to replace it with material of right specifications without any further cost to M.I.Ltd., within specified time or :
 - ii. Buy the entire or part quantity of material rejected or any other material for similar purpose at the risk and cost of the tenderer without affecting tenderer's liability as regards supply of balance consignment due under the contract.
- b) Consignment rejected as aforesaid, must be removed by the supplier within 15 days from the date of communication of rejection by MIL, against replacement

of equal quantity, and such rejected material shall lie at the tenderer's risk and cost from the time of such rejection and if not removed within the aforementioned time, MIL shall have the right.

- i) Either to return the rejected material on freight to pay basis, or,
- ii) To dispose of such material at tenderer's risk and cost, or :
- iii) To retain such portion of the proceeds as may be necessary to recover any loss or additional expenses incurred by MIL in connection with such sale or adjust the proceeds against ones from the supplier.
- iv) The rejected goods if not lifted by the supplier within 15 days from the date of intimation, shall incur storage charges of Rs.50/- per MT per day plus loading, unloading charges.
- v) MIL shall be at liberty to dispose off or to destroy the rejected goods if not lifted within 15 days at risk and cost of tenderer.
- vi) If the supply is consistently of poor quality, the balance quantity of order will be cancelled and the tenderer may be debarred from the participation of any future tenders of MIL.
- vii) The rejected material if not replaced by tenderer within 15 days, MIL may at its sole discretion, can accept the material at the reduced rate or with quality cut which MIL feel suitable.
- viii) **It is sole discretionary right of the purchaser to blacklist the tenderer if material supplied by him fails three (3) times in a financial year to comply specification / norms / composition provided in tender document.**

24) WITHHOLDING OF LIEN IN RESPECT OF SUMS CLAIMED:

Whenever any claim or claims for payment of sum of money arise out of or under the contract against the tenderer, the purchaser shall be entitled to withhold also for a lien to retain a sum or sums in whole or in part from the pending bills and 'Security Deposit' of the tenderer for the aforesaid purpose the purchaser shall be entitled to withhold said pending bills and Security Deposit and also for a lien over the sum pending finalization or adjudication of any such claim. In the event of pending bills and Security Deposit being sufficient to cover the claim amount or amounts or if no pending bills and Security Deposit are there from the tenderer, purchaser shall be entitled to withhold and have a lien to retain to the extent of such a claim amount or from any sum of amount referred to be found payable or which at any time thereafter may become payable to tenderer under this contract or any other contract with the purchaser. If it is an agreed terms or the contract against the sum of money or moneys so withheld or retired under the lien referred to above, by the purchaser till the claim arising out of or under the contract is determined by the arbitrator or competent court as prescribed hereafter, the tenderer will have no claim interest or damages whatsoever or any action in respect of such withholding or retention under the lien referred to and duly notified

as such to the tenderer, for the purpose of this clause whether the tenderer is partnership firm or limited company, the purchaser shall be entitled to withhold and also have lien to retain towards such a claim the amount or amounts in hold or in part from any sum found payable to any partner limited company as the case may be whether in individual capacity or otherwise.

25) The tenderer shall agree that it will indemnify and hold purchaser harmless at all times from and against all claims, demands, actions, suits and proceedings of whatsoever nature made, which purchaser may suffer or incur and which arise out of tenderer's breach of any Terms & Conditions of this contract or breach of any representations or warranties made by the tenderer or any liability incurred or claimed against purchaser by any person whatsoever with regard to quality contents, characteristics of the material supplied under this contract or for any breach or alleged breach or infringement of any Intellectual Property Rights (IPR) of purchaser or of a third party howsoever and whatsoever or any other damage, cost etc. paid and any liability/damages/cost of expenses suffered by purchaser directly or indirectly as a result of arising out of the foregoing or breach or nonobservance. Without prejudice to the above, it will also be specifically agreed by tenderer that it will indemnify purchaser against any loss suffered by purchaser on account of quality problems such as nutrient deficiency, weight, moisture, water soluble contents etc. and all other liabilities including legal expenses arising out of non-confirmation of CIB/BIS specifications.

26) LAWS GOVERNING THE CONTRACT:

This contract shall be governed by the laws of India for time being in force. Irrespective of the place of delivery, the performance or the place of payment under the contract, the contract shall be deemed to have been made at the place from which the acceptance of the tender has been issued.

27) JURISDICTION OF COURTS:

The courts of the place at Mumbai, Maharashtra shall alone have jurisdiction to decide any dispute arising out of or in respect of the contract.

28) Executive Director/Officer may at any time by notice in writing similarly determine the contract without compensation to the tenderer in any of the following events i.e. to say:

- 1) If the tenderer being an individual, or if a firm any partner thereof, shall at any time, be adjudged insolvent or shall have a receiving order or ordered to administration of his a state made against him or shall take any proceedings for composition under any insolvency at for the time being in force or make any conveyance or assignment of his effects or enter into arrangement or composition with his creditors or suspend payments or if the firm is solved under the partnership act.

OR

- 1) If tenderer being a company is would up voluntarily or by the order of tenderer receiver, liquidator or manager or behalf of the debenture holder is appointed or circumstances shall have arisen which entitled the court or debenture holder to appoint receiver, liquidator or manager.

- 2) If the tenderer commits any breach of the contract not herein specifically provided. For provided always that such determination shall not prejudice any right of action or remedy which shall have approved or shall accrue thereafter to the purchaser and provided also the tender also liable to any, the purchaser for any extra expenditure he has thereby put and the tender shall under no circumstances be entitled to any gain on purchaser's purchase.

29) ARBITRATION:

In the event of any dispute or differences arising out or relating to, under or in respect of this contract, the same shall be referred at the written request of either party to a sole arbitrator to be appointed by Executive Director of MIL Ltd. in accordance with the Arbitration and Conciliation Act, 1996 and the Rules, if any, made there under and any statutory modifications or re-enactment thereof. The venue of arbitration proceedings shall be at Mumbai. Any arbitration award made in such arbitration proceedings shall be final and binding on both the parties.

If at any point, proceeding, during or after the currency of the present tender it is found that the concerned supplier has tried/has approached any of the official of the MIL to influence outcome of the tender, the supplier concerned shall be summarily debarred from any further dealings with the MIL.

The tenderer and the purchaser shall not be responsible for delay and/or breach of performance on account of force majored conditions if and to the extent caused by matters beyond the reasonable control of the parties but not limited to the acts of God, acts of Govt. authority, strikes, lockouts, trade disputes or concerned acts of workmen lasting over 15 days, fires, floods, severe draughts, earthquake, explosion, riots, war break down. However, the party affected by such force majored situation shall intimate the other party forthwith. In the event to supply the required quantity on account of labor problems or situation arising out of force majored, intimation in writing given to purchaser by the tenderer, and on such intimation the liability to supply under this contract shall ceased until such problem or circumstances prevailed. If labor problems persists for more than 2 months and the tenderer is unable to fulfill its obligations, purchaser will have option to terminate this contract by giving written notice to this effect.

We acknowledge that, we have read and understand all the terms and conditions of the tender and hereby confirm that the same are accepted and binding on us.

Authorized Signature of tenderer with seal

**Note: - The tenderer should sign and place seal on each page before uploading
The documents.**

“Special Notes to Bidders”

- ❖ Bidder should must have Selling experience of Pheromone Traps & Lures to MIL/MAIDC/ Govt. of Maharashtra , Any Govt. Department / Authority for Preceding last three years.
- ❖ Bidder should have their own manufacturing Capacity to supply the same.
- ❖ These products are mainly purchased to supply under various Govt. Schemes, so all the Quality parameters are as per specifications only.
- ❖ Govt. authority place there demand as per there requirements, so **required quantity is not confirmed**, our requirement is also based on Govt. Orders only.
- ❖ The payment of supplied material will be made by the MAIDC/MIL Ltd. after receipt of payment from Govt. agencies/ Private Dealer, i.e. on “**Back to Back basis**”. Bills for the supplied material should be prepared in triplicate and sent to the Gen. Manager (F&A/Pesticides), MAIDC Ltd., Goregaon (E), Mumbai 65, and one copy sent to the MIL, Akola. **The payment will be made on receipt of Goods receipt Note (GRN) & Payment Confirmation Certificate (PCC)** from Regional Office along with Pre-Inspection report of concern product. The MIL/MAIDC Ltd. shall not incur any liability to pay interest on the bills for delay in payment. Payment will be made on submission of satisfactory documents and the concerned officer passes it. Payment will be made after fulfilling the following conditions:
 - i. GST or any other taxes, duty or earlier if specified in purchase order and handling charges will have to be borne by the supplier.
 - ii. If shortage or breakage has been reported, the goods should be replaced at his own cost.
 - iii. If the material is found to be substandard, old or defective the material will not be accepted and supplier will have to replace the material at his own cost.

❖ **As per the past experience of Govt. Orders for Traps & Lures, MIL/MAIDC should have to supply huge quantity in limited time all over Maharashtra so, to manage demand and supply MIL/MAIDC shall have right to distribute quantities of supply over / in eligible participated tenderers on L-1 rate.**

❖ Pre-supply sampling for each batch of each product pre-supply sampling is carried by our local Regional Managers / Authorized person. Initially testing charges born by MAIDC/MIL & further recover from concern suppliers from their supply bills.

❖ For each batch of product quantity is not more than 1,00,000/- units/Nos.

We acknowledge that, we have read and understand all the “Special Notes to Bidders” of the tender and hereby confirm that the same are accepted and binding on us.

Authorized Signature of tenderer with seal

**Note: - The tenderer should sign and place seal on each page before uploading
The documents.**